



EG-LRF 20000

**technical description
and instruction manual**

1. INTRODUCTION

This manual provides basic information that is necessary for proper operation and preventive maintenance of the EG-LRF 20000 compact laser rangefinder.

A full description of the device operation and details of extensive repair and technical servicing procedures are not given in this manual.

2. DESCRIPTION

2.1. General

The EG-LRF 20000 laser rangefinder is a device intended for the use by an individual. The rangefinder can measure ranges from 60 to 20,000 m with an accuracy of 5 m. The maximum range depends on a target size and shape as well as weather conditions, and can exceed 20,000 m in case of good target visibility.

The solid-state laser used in this EG-LRF rangefinder is classified as 1 Class of laser hazard and its emission is eye-safe for people being within the laser beam.

The EG-LRF 20000 delivery set includes (see Fig.1):

- rangefinder;
- accumulator battery (2 pieces);
- accessory set;
- charger for accumulator batteries;
- technical description and instruction manual;
- carrying case.

2.2. Rangefinder

The external view of the rangefinder is shown in Fig.2.

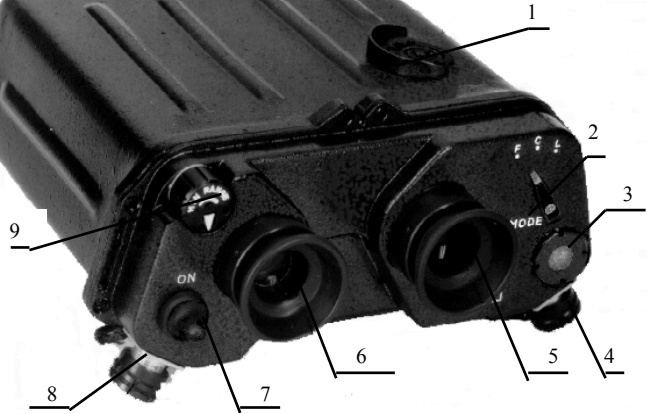

Fig.1. EG-LRF 20000 rangefinder set:

1. Carrying case. 2. Rangefinder. 3. Accumulator battery.

4

a)



b)

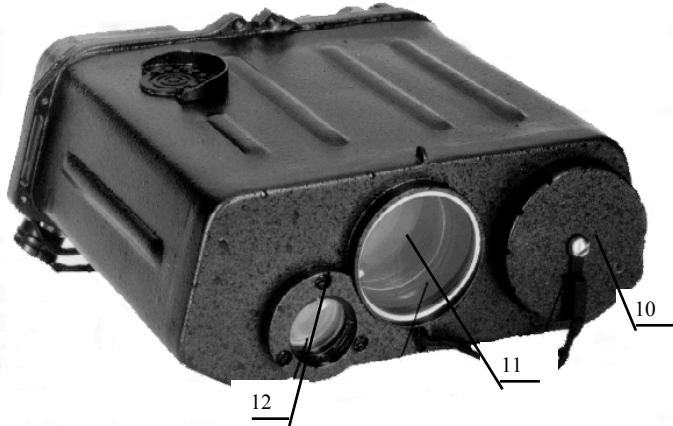

1 – trigger; 2 – **MODE** operating mode switch; 3 – desiccator with silica gel; 4 - plug to output information on range; 5 -boresight eyepiece; 6– digital display ocular; 7 - **ON** supply switch; 8 – external power supply and remote trigger plug; 9 – **MIN RANGE** minimum range (gate) handle ; 10 - battery compartment lid; 11 – receiving and sighting channel objective; 12– transmitting channel objective.

Fig. 2 - External view of rangefinder

a) viewed from the eyepiece panel; b) viewed from the front panel.

The rangefinder has the following controls: the **ON** power supply switch; the **MODE** operating mode switch; the **MIN RANGE** handle for continuous setting a minimum range (gate) on the eyepiece panel of the rangefinder as well as the trigger on the topside of the rangefinder housing.

2.3. Battery

The rangefinder uses a NiCd rechargeable battery. The battery has a rated voltage of 12 V and a capacity of 0.55 A·h that is sufficient for more than 300 rangings at +20°C.

2.4. Accessory set

The accessory set includes the following items:

- 1) Supply cable and cable to output information on range;
- 2) Cloth to wipe optical surfaces;
- 3) Silica gel to replace the wet one in the desiccator.

2.5. Charger for accumulator batteries

The AD-150-VD portable charger is designed to charge Ni:Cd battery of 12 V voltage and capacity from 0.5 to 1.0 A.h. The charger is a stabilized DC source.

Technical characteristics of the AD-150-VD:

Mains voltage	200...240 V
Charge current	60 mA±5%
Ambient temperature when operating	+5...+25°C
Power supply	no more than 1 W

2.6. Carrying case

The case is used for transportation and storage of the rangefinder. It protects the latter from various mechanical damages during transportation and storage. The whole of the rangefinder set is placed in the case.

It is possible to deliver the rangefinder in a metal case.

3. DESIGN AND OPERATION

3.1. Principle of operation

The rangefinder operates on the same principle as the optical locator. A range is determined by the time of passing of a short invisible laser pulse to a target and back.

A short infrared light pulse of high intensity generated by the laser propagates towards a target within a narrow cone. At the same time a small portion of the pulse hits the photosensitive area of the photoreceiver and is transformed into an electric pulse (start signal). The light pulse reflected from the target comes to the receiving objective of the rangefinder and is transformed into an electric pulse (stop signal). The time interval meter measures the time between these two pulses and transforms it into the information on range.

3.2 Design and operation

The rangefinder block diagram is given in Fig.3.

The rangefinder consists of the following main parts: the transmitting (11, 12, 13, 14, 15) and receiving (9, 8, 7, 4) channels, the boresight (5, 6, 7, 8, 9), the display and control unit (3).

The rangefinder optical configuration (Fig.4) provides formation of a laser pulse and sighting it on the target, transmitting the start pulse, receiving a light pulse reflected from the target and focusing it on the photoreceiver photosensitive area, observing the readings on the digital display.

The transmitting channel (7) optics forms a laser pulse while reducing its divergence. To ensure the parallelism of the receiving and transmitting channels, there are two protective glass wedges (8) at the exit of the telescope of the transmitting channel.

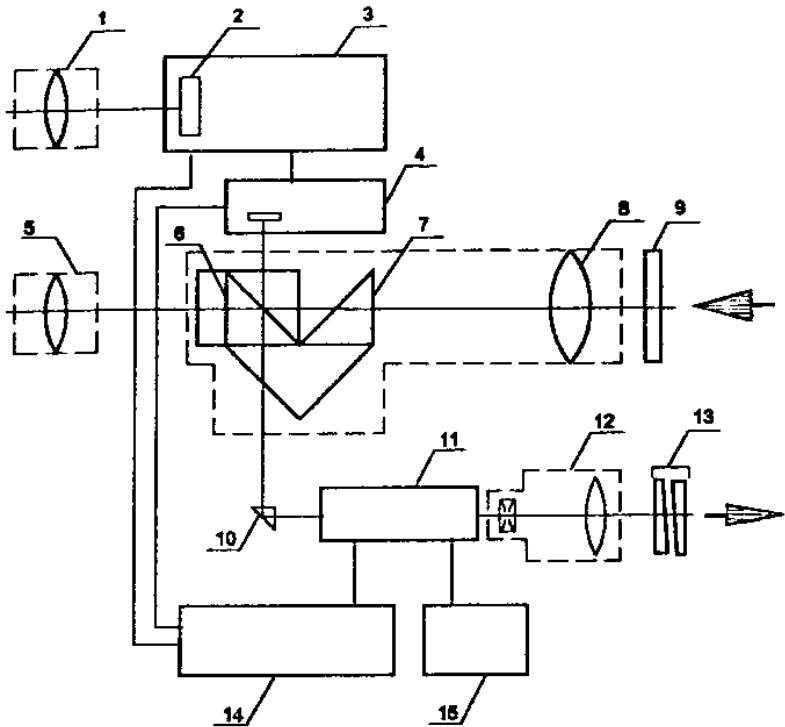

Fig.3. Rangefinder block diagram:

1 - digital display ocular; 2 - digital display; 3 - display and control unit; 4 - photoreceiver; 5 - boresight eyepiece; 6 - sight reticule; 7 - prism unit; 8 - receiving/sighting channel objective; 9 - protective glass; 10 - start-pulse forming prisms; 11 - laser head; 12 - telescope; 13 - adjusting wedges; 14 - laser head power supply; 15 - Q-switch control unit.

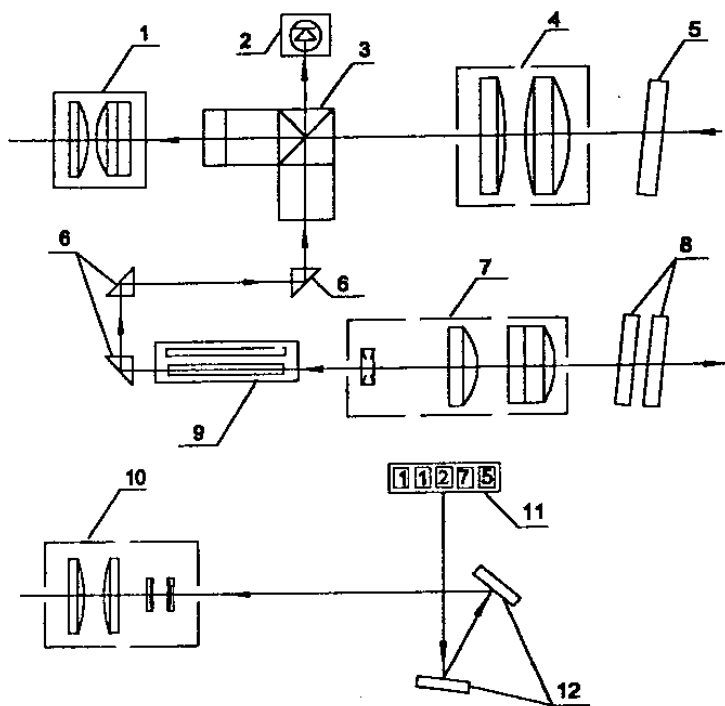

Fig.4. Optical configuration of rangefinder :

1 - boresight eyepiece; **2** - photoreceiver; **3** - prism unit; **4** - receiving/sighting channel objective; **5** - protective glass; **6** - start-pulse forming prisms; **7** - telescope; **8** - adjusting wedges; **9** - laser head; **10** - digital display ocular; **11** - digital display; **12** - mirrors.

In the transmitting channel a laser pulse reflected from the target goes through the protective glass (5), the receiving/sighting channel objective (4), the prism unit (3) and is focused by the objective in the plane of the photosensitive area of the photoreceiver (2).

The prism unit by its beam-splitting coating applied to the facet of one of the prisms divides a laser pulse going through the objective into two portions. A laser pulse at 1.054 μm passes to the photoreceiver, and a visible laser pulse is reflected and focused in the plane of the eyepiece (1) reticule.

The boresight includes the objective (4) and the erecting prism unit (3) integrated with the receiving channel, and the sight eyepiece (1).

The digital display unit consists of two mirrors (12) transmitting the image of the digital display (11) to the eyepiece, and the display ocular (10).

The rangefinder operates in two modes: ranging mode (the **MODE** switch is in the **F** or **L** position) and control mode (the **MODE** switch is in the **C** position)

When operating in the **F** mode, range measurement to the first target within the rangefinder transmitter beam is carried out.

When operating in the **L** mode, range measurement to the last target within the rangefinder transmitter beam is carried out.

When operating in the **C** mode, the value of minimum range is shown on the digital display. By the **MIN RANGE** handle a necessary value of minimum range is set within 40...4500 m.

3.2.1. Rangefinder operation in ranging mode (mode switch in F or L position)

When the **ON** switch is switched on, the storage capacitor is getting charged during ~ 10 s. When it is charged, the ready indicator lights (Fig.4), and then the storage capacitor is continuously recharged. To measure a range to a target, the rangefinder cross-hairs at the center of the field of view of the sight eyepiece is set on the target. When the trigger button is pressed, the storage capacitor is discharged through the flash lamp of the laser, and a laser pulse is generated. The major portion of a laser pulse is sent from the output of the transmitting channel of the rangefinder to a target. At the same time a small portion of the laser pulse hits the photosensitive area of the photoreceiver and is transformed into an electric start pulse. The light pulse reflected from the target is focused on the photosensitive area of the photoreceiver and is transformed into an electric stop pulse. The time interval meter in the display and control unit is started by the electric start pulse from the photoreceiver

and continues operating until the stop pulse from the photoreceiver stops the count of pulses from the timing oscillator of the time interval meter. The time interval between the start and stop pulses is transformed into the information corresponding to a range to a target in metres that is displayed.

Besides the measured range, additional information is shown on the digital display by the LEDs (Fig.5).

3.2.2. Rangefinder control in the CONTROL mode (the switch in the position C)

After setting the supply switch to the position ON the value of minimum range is output to the digital display. The value of minimum range depends on the MIN RANGE position of the potentiometer handle and can be changed from 40 m for the extreme counter-clockwise position of the handle to 4500 m for the extreme clockwise position of the handle. The accuracy of minimum range setting is ± 20 m.

When pressing the START button in the CONTROL mode, the control range is measured to check the serviceability of the rangefinder timer. In this case there is no laser pulse. The START and STOP electrical pulses are formed not by the photoreceiver, but by the central processor of the rangefinder. If a value of minimum range is less than 280 m, the digital display outputs a control range of 304 ± 5 m. If a value of minimum range is more than 320 m, but less than 3500 m, the control range is to be 3750 ± 10 m. For minimum ranges more than 4000 m the control range is $18,432 \pm 10$ m.

A deviation of displayed values of control ranges more than ± 10 m from the said nominal values is indicative of failure of the rangefinder.

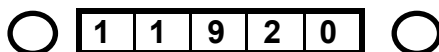

Ready indicator
(green LED)

Run-down battery indicator
(red LED)

a) Digital display readings in range measurement to one target



C-indicator

b) Digital display readings when the rangefinder detects a signal reflected from a target gated out by the minimum range setting



M-indicator

c) Digital display readings when the rangefinder detects a signal reflected from an object behind the measured target



d) Digital display readings when there is no start signal at the photoreceiver input



e) Digital display readings when there is no signal reflected from the target

Fig.5. Display of ranging results and rangefinder serviceability

4. TECHNICAL DATA

4.1. Transmitter

Wavelength, μm	1.54
Pulse energy, mJ,	5-8
Pulse width, FWHM, ns.....	~ 30
Pump energy, J, no more.....	12
Pulse repetition rate, Hz.....	0.15
Beam divergence (80 % energy),mrad..	1

4.2. Receiver

Field of view of receiving channel, mrad.....	1
Type of photodiode.....	Avalanche Ge or PIN photodiode
Entrance pupil diameter, mm.....	43
Range accuracy, m.....	± 5
Measurement range, m.....	60...20,000
Type of digital display.....	LED indicators observed through eyepiece
Multiple target.....	1 target displayed, indica-tion of more than 1 target registered
Operating mode.....	first/last target
Minimum range setting, m.....	40...4500
Minimum range setting accuracy, m...	± 20

4.3. Sight

Magnification.....	7.5 ^x
Field of view.....	5.5°
Objective diameter, mm.....	43
Range of eyepiece dioptric setting.....	± 4

4.4. Power supply

Built-in battery.....	NiCd 12 V/0.55 A·h re- chargeable battery
Rangefinder weight without battery, kg, no more.....	1.9
Range information output	RS232 interface

5. DIRECTIONS FOR USE**5.1. Safety measures**

Since the laser head power supply produces high voltage that is a threat to human life, **it is categorically prohibited to disassemble the housing of the rangefinder** when there is an accumulator battery.

5.2. Measurement procedure

- 1) make sure that the **MIN RANGE** handle is set to the extreme left position or to a required minimum range value (see 5.3);
- 2) set the **MODE** switch to the **F** position (range measurement to the first target);
- 3) set the supply switch to the **ON** position. The rangefinder power supply is on;
- 4) rotate the eyepieces to obtain a sharp image of the eyepiece reticule and of the digital display;
- 5) look into the right eyepiece and set the cross-hairs exactly on a target. When the green ready indicator in the digital display ocular lights, smoothly press the trigger button. Do not release the trigger button and take the readings from the display. The range in meters is displayed when holding the trigger button pressed;
ATTENTION! If the trigger button is pressed before the green ready indicator lights, measurement will be made with a delay until the green indicator lights.
- 6) if the **M**-indicator (multiple target) lights, carefully examine the target area through the sight eyepiece to identify other targets (see Fig.6). For positive identification of all targets the arrangement for minimum range setting can be additionally used as explained in 5.3;
- 7) if the **C**-indicator lights, this means that one or more targets (without indication of their number) are gated out by the minimum range setting. Examine the target area through the sight eyepiece to identify the targets. If it is necessary to measure a range to a target that is less than the minimum range, reduce the minimum range setting and repeat the ranging procedure.

5.3. Use of arrangement for minimum range setting

To obtain reliable results, it is of first importance that an operator completely understands the designation of the arrangement for minimum range setting. Laser emission is reflected from various targets, and the receiver in the rangefinder is not able to distinguish them from each other, so the shortest range will be displayed, whether it be an obstacle or a target.

The arrangement for minimum range setting is designed to facilitate identification of individual signals reflected from targets and other objects in the path of the laser beam.

By using this arrangement an operator is able to not receive (i.e. reject) signals reflected from objects within a given minimum range (gated range). A value of gated range can be set within 40...4500 m. For this purpose:

- set the **MODE** switch to the **C** position;
- switch on the **ON** switch;
- observe the value of minimum range in the left eyepiece;
- continuously rotating the **MIN RANGE** handle set a required value of minimum range;
- set the **MODE** switch to the **F** position and measure the range to a target as explained in 5.2.

Due to the fact that a portion of the transmitter beam is intercepted by objects in front of a target, a signal from the target can be lower than the level of operation of the rangefinder receiver, so, when measuring range, sight the rangefinder on a target so that as few objects in front of the target as possible are within the transmitter beam.

If the **C**-indicator lights, this means that one or more targets (without indication of their number) are gated out by the minimum range setting.

Controls position		Digital display readings	Notes
MODE switch	MIN RANGE handle		
F	≤ 60	2200•	Target 2200 m. There is a target behind the displayed one (3500 m)
F	2250	•3500•	Target 3500 m. There is a target behind the displayed one (4200 m) and a target within the gate (2200 m)
F	3550	•4200	Target 4200 m. There is a target within the gate (3500 m)
L	≤ 60	4200•	Target 4200 m. There is a missed target (3500 m)
L	2250	•4200•	Target 4200 m. There is a missed target (3500 m) and a target within the gate (2200 m)

Fig.6. Example of ranging with multiple targets

5.4. Measurement of range to the last target

If a target to be measured is overlapped by close targets, the signals from which come to the rangefinder, and there is no object within the transmitter beam behind the target (i.e. the reflected signal from this object does not come to the rangefinder), then a range to such a target is the easiest to be measured in the last target measurement mode (the **L** mode).

Set the operating mode switch to the **L** position and make ranging according to 5.2.

5.5. Switching-off

The handle of the power supply switch should not be left in the **ON** position for a long time since in this case the battery is quickly discharged. That's why the rangefinder supply should be switched off on completion of rangings.

6. MAINTENANCE

6.1. General

It is prohibited to disassemble the rangefinder.

6.2. Operator's maintenance duties (preventive maintenance)

The necessary maintenance of the rangefinder includes execution of the following operations:

- 1) in case of detection of damages, faults or performance degradation, inform the manufacturer;
- 2) in case of contamination, wipe the optical surfaces, the housing, the control handles of the rangefinder with the cloth from the Accessory set;
- 3) if the silica gel colour changes from blue to pink (in this case the silica gel is saturated with moisture), replace the silica gel in the desiccator after prior heating the replacement silica gel from the Accessory set until it becomes blue;
- 4) carry out charging the accumulator battery (when the battery discharge indicator lights (see Fig. 5).

Carry out charging when the **ON** supply tumbler is switched off in the following manner:

- set the charged accumulator battery into the rangefinder;
- insert the charger into the socket;
- connect the charger to the rangefinder through the plug to connect the cable of external supply =**12** (see Fig. 2). In this case the (Charge) indicator on the

charger lights;

- charge time of the discharged battery is 14...14.5 h;
- disconnect the charger from the rangefinder.

5) after long-duration interval in operation with the rangefinder (more than one month) it is necessary to carry out training of the energy storage capacitor of the head supply unit.

Carry out training in the following manner:

- a) shift the supply tumbler of the rangefinder to the **ON** position;
- b) after 10...15 s press and release the start button;
- c) repeat the operations according to the clause b) until the green readiness indicator on the digital indicator display lights (see Fig.5), after that the rangefinder is ready to measure.

Appendix 1

DESIGNATION OF PINS OF RANGEFINDER EXTERNAL PLUGS

1. The plug to connect the external power supply and the remote trigger button

- an external supply voltage of 12 ± 2 V is applied to the pins 1,4 of the plug;
- the remote closure trigger button is connected to the pins 2,3 of the plug;
- a consumed current (average) is no more than 0.6 A.

Numbering of the pins of the plug to connect the external power supply and the remote trigger button

The plug to connect the external power supply and the remote trigger button
(viewed from the side of the pins)

Circuit	Pin
+ 12 V	1
TRIGGER	2
TRIGGER	3
0	4

2. The plug to output information on measured range

The information on measured range is transmitted from the rangefinder to the computer by direct connection to the COM1 (3F8h) 9-pin port.

To operate the computer, it is necessary connect the computer with the rangefinder by the cable, to start the LRF.EXE control program on the disk, and switch on the rangefinder.

LRF.EXE is the EG-LRF rangefinder control program to provide communication of the rangefinder with the IBM PC having the WINDOWS XP operational system. For normal functioning of the program a free disk space of about 700 Kbytes for the control module and a space that is unknown beforehand for storage of the LRF.LOG output files are necessary.

In the LRF.LOG files the measurement data of the whole of the program session is recorded.

See the description of operation of the LRF.EXE program in the file Help.txt.

Numbering of the pins of the plug to output information on range

The plug to output information on range
(viewed from the side of the pins)

Circuit	Pin
RxD	2
TxD	8
SG	10

ACCEPTANCE CERTIFICATE

Product: Hand-held laser eye-safe rangefinder

Model: EG-LRF

Serial number _____

Name of parameter	Permissible values	Actual values
Maximum range, m, no less	10,000	
Minimum range, m, no more	60	
Minimum range setting, m	40...4500	
Time of rangefinder readiness for measurement, s, no more	6	

The product conforms with the technical requirements and is fit for operation.

Supplier
 Laseroptronix
 Enhagssligan 23
 187 409 Täby
 Sweden